

CP600 (Attenuator)

Conductive Plastic

Low rotational noise level

Small size

16mm square

High Quality

All parts are highly precise.

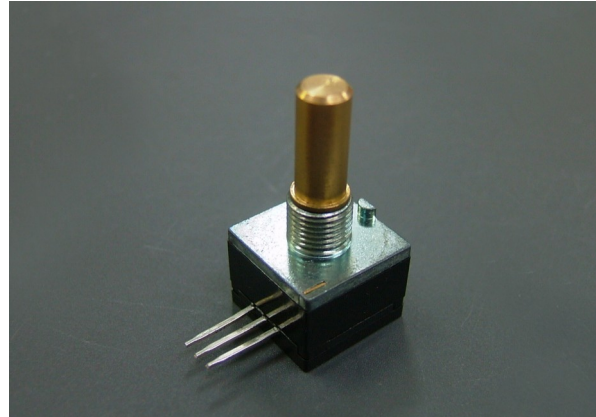

Dimensions

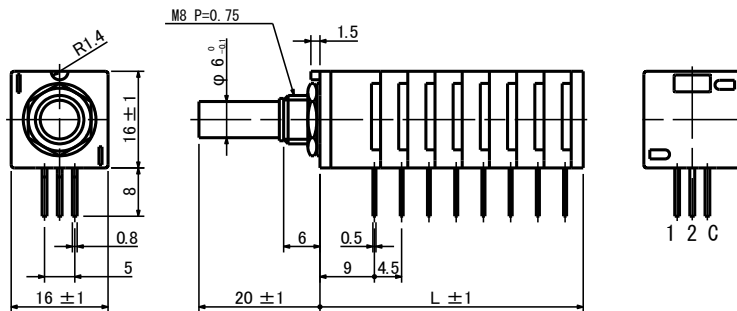

Circuits	1	2	3	4	5	6	7	8
L	12	16.5	21	25.5	30	34.5	39	43.5

Output Law

Degrees (CW-CCW)	0	15	30	45	60	75	90	105	120	135	150	165	180	195	210	225	240	255	270	285	300
Attenuation [dB]	0	2	4	6	8	10	12	14	16	18	20	22	24	26	28	30	33	37	42	50	Cut off

The products and their specifications are subject to change without notice.
TOKYO KO-ON DENPA CO., LTD. www.tkd-corp.com ED01B-201104

ATTENUATOR

Model number

2	CP601	C	-	10K
Number of circuit (2~8) Blank: single circuit	Product type	Mechanical click option Blank: Without click C: With Center click S: With click (15degrees step)		Total resistance

Circuit method

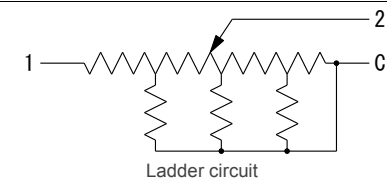

Electrical specifications

	CP600
Circuit (Unbalanced)	Ladder circuit
Attenuation direction	CCW (Large attenuation & cut off) - CW (Small attenuation)
Total resistance (1-C)	5k, 10k, 50k, 100kohm
Total resistance tolerance	±20%
Attenuation accuracy	0~10dB: ±1.0dB, ~30dB: ±2.0dB
Matching accuracy	0~10dB: 0.6dB, ~30dB: 1.0dB
Insertion loss	0.5dB or less
Cut off (15Hz)	85dB Min.
Voltage proof	1 Min. at AC500V
Insulation resistance	50Mohm or more at DC500V
Max rating	DC20V
Rotational noise level	47mV or less (by JIS C 6443)
Rotational life	100,000 Cycles Min. (18cycles/min, Sliding noise level: Less than 100mV)

Mechanical specifications

	CP600
Operating angle	300 degrees ±5 degrees
Rotational torque	0.1~1.2Ncm (Different by number of circuit)
Strength of Nut-Attached	50Ncm
Attached Parts	Hexagonal nut (M8)
Stopper strength	50Ncm
Push-pull strength	50N

General specifications

	CP600
Temp. range	-10 to +70 degrees C (Operating), -15 to +75 degrees C (Storage)
Relative humidity	90%RH (No condensation)

Note

- * This product is constructed by a ladder circuit. Cannot use it for a rheostat use (a use to change a resistance level).
- * Solder heat resistance: 350degrees C max, 5sec max, to 2 times. (Manual soldering only)
- * Special order of the shaft length is possible. Please contact us for details.